

Compact, Rugged Digital Sine Drive for High Reliability Applications

Jay Goetz
Sr. Staff FAE

International Rectifier
High Reliability Products
Minnetonka, MN 55345
Jgoetz1@irf.com

Weiping Hu
Design Engineering Manager

International Rectifier
High Reliability Products
Leominster, MA
whu1@irf.com

Deb Battacharyya
Sr. Hybrid Electrical Design
Engineer

International Rectifier
High Reliability Products
Leominster, MA
Dbatta1@irf.com

As presented at PowerSystems 2004

Abstract

The “electric” architectures of future air land and sea vehicles demand highly efficient speed controls for continuous duty machines such as fuel pumps, airflow machines/fans, and compressors. Controls are being positioned near loads at the extremities of these vehicles, operating in harsh conditions such as high starting torque, dry-run and extreme cold startup, all the while shrinking physical footprints in order to save bulk and weight. Airframe manufacturers also are asking suppliers to replace Induction motors, because of issues with power factor, inefficiency, and limited power performance (torque/amp ratios). But these older systems are reliable so a way is needed to maintain their simple sensor-free reliability while achieving the performance gains promised with digitally controlled PM motors. This paper introduces a new sensorless closed loop vector speed controller implemented in a configurable control platform using a hardware processor....no software is required. Sinusoidal current waveforms are used to achieve low torque ripple and reduced EMI, even with low inductance and light loads which traditionally have complicated the ability to remotely sense rotor position. High torque is achieved over a wide speed range, with 400% torque overload down to 5% of Full Speed while allowing high shaft speed (high inverter frequency) and achieving robust and smooth startup. Controller requirements and features are discussed and test results of the commercial platform implementation of this controller are given.

Permanent Magnet Motors Drive High Reliability Electric Applications

Due to their improved torque/inertia and power/size ratios, electronically commutated permanent magnet motors are now preferred in many variable speed applications that induction motors or hydraulics have dominated in the past. The inverterized appliance installed base is increasing rapidly, most new designs containing PM motors, and is expected to grow fivefold to 150 Million units annually in the next 10 years. This popularity has driven magnet material cost down, which, coupled with automated metals manufacturing, is spawning growth of new applications:

- Fuel cells and electric motors will not replace jet engines on commercial transports, but they could one day replace gas turbine auxiliary power units, Boeing officials say (5) efforts underway include evaluation of Brushless PM motors for this application
- Officials in the Canadian military develop an electric drive for a quieter and more accurate turret for their new Light Armored Vehicle (LAV). "The advances in both power and low-level semiconductors, and advances in brushless motors allows hydraulic power systems to be replaced by electric power drives," (6)
- Motor vendors now provide PM motors such as the “Silencer” motor for applications that require low audible noise, long life, and high torque is available from PolyScientific built for centrifuge applications and high-speed fans and pumps(4)
- Fly-by-wire servo actuators for control of the aircraft's (Airbus A400) primary flight surfaces from Moog utilize PM motors. These include conventional electro hydraulic

actuators for the aileron, elevator, and certain spoilers, plus advanced technology electro hydrostatic actuators for positioning additional spoiler panels.(7)

Flexible Integrated Motion Control Platform

Design platforms are being created with all the important machine control factors to the application designer including bandwidth, torque/speed relationship, noise and torque ripple, power factor, efficiency, protection features, etc. (1)

These platforms provide the following:

- Scalable Power Electronics – IGBT or MOSFET Power Stage
- Variable Performance –speed, PWM, dead time adjustments
- Configurable Sensing – phase or leg shunt selection
- Adjustable Fault Handling – configurable startup/operate monitors
- Protections with override – bus overvoltage/overcurrent/improper supply voltage response choices

Figure 1) shows the basic features needed in diagram form.

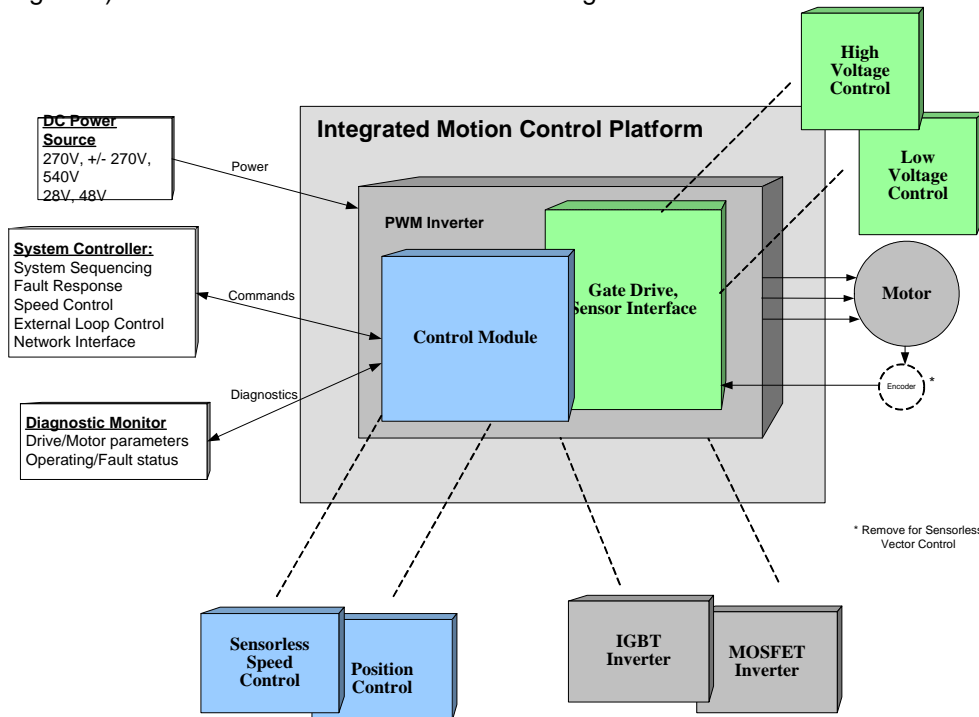

Figure 1) Configurable Motion Control Platform

Motion Control Engine for High Reliability Sensorless Speed Control

The Sensorless Vector Control Algorithm shown in the control module of figure 2) provides the motion control engine for the platform.

Use of sensorless technology eliminates the need for commutation and position feedback devices (such as Hall Sensors), which in turn reduces motor size, cost, and interface complexity, and improves overall reliability. The use of IR's proven commercial technology (sensorless algorithm) provides a mature design to start from..

To control costs, commercial components are used where they do not adversely affect the system reliability. An example of this is the use of the IR's iMotion chipset. In cases requiring extended temperature or radiation exposure, Radiation Hardened or specially packaged components can be used.

The Controller will be manufactured on IR's High Rel Manufacturing (Mil-PRF 38534 certified) line resulting in a more stable design and ensuring better yields and fewer field failures. Designs are

qualified and screened to Class H requirements to ensure each controller operates over the specified environment.

Sensorless Speed Controller

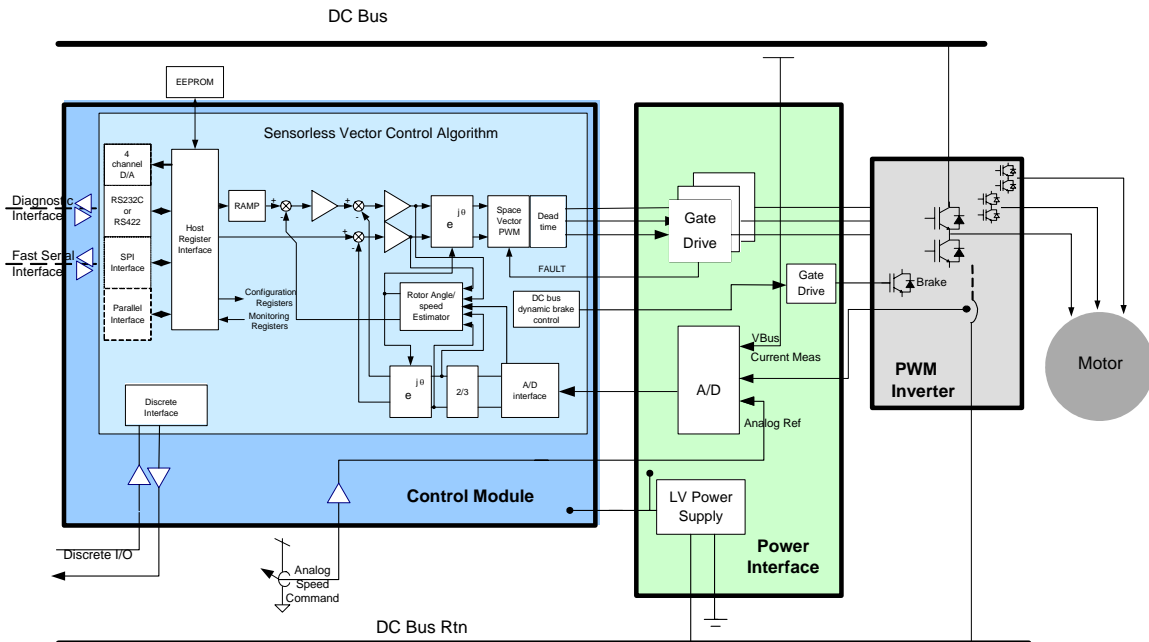

Figure 2) Sensorless Speed Controller Block Diagram

Analog control of speed and torque is inflexible and often hard to tune and requires the use of commutation sensors (Hall sensors) and sometimes speed sensors (encoder, resolver, potentiometer).

Recent developments in digital control have allowed practical implementation of true Sensorless Vector Control with sufficient bandwidth performance to match traditional analog drives. Advances in programmable logic arrays and their support tools, have prompted conversion from software systems to even faster, parallel hardware processing systems needed to develop advanced features such as single shunt current sensing algorithms.

Figure 2 shows the use of only a single current and voltage measurement, which is capable of at 20Khz PWM modulation. 3-leg or 2-phase current measurement is used to achieve PWM rates as high as 100Khz.

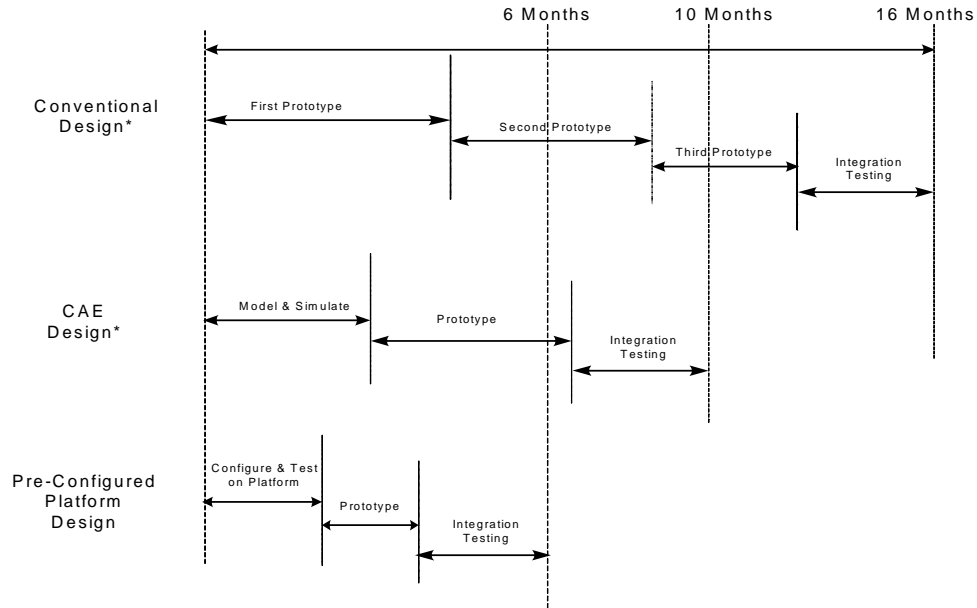

Figure 3) Estimated Development Time - *derived from Ansoft Inc. presentation “Rapid Design and Prototyping of Motors and Drives” (2)

To illustrate the timesavings possible with a pre-configured platform approach, three approaches to developing a new motor drive are shown in Figure 3). Here we see the dramatic reduction in design cycle time as multiple prototype spins are eliminated.

A platform approach eliminates the need for digital drive specialists such as DSP Programmers, Power Electronics Designers, and Thermal/Mechanical Designers. Using such a platform, the development can be driven directly by the application experts (system engineer, aerospace engineer, etc), thus avoiding “interdisciplinary cracks” which can plague conventional design teams. (3)

Using an iMotion platform, BE Aerospace has been able to create a new digital controller for their airborne cooling systems used aboard the Airbus A380. As their staff didn’t include software programmers familiar with DSP programming, they chose to use IR’s pre-configured design platform. The design is now complete and prototype build is planned for early 2005. Features of the new design include improved power factor, and reduced size and weight, all of which support the design mission of their customer, the airframe manufacturer.

Performance Capabilities – for Sensorless Speed Control

The following performance goals are being implemented in this platform:

- Control of high speed, low inductance motors (up to 25,000rpm) using cost effective sensors
- High torque at low-speed (400% intermittent at 5% of full speed).
- Robust startup sequence with fast detection of start-up failure and start-up retry.
- Total speed error < 5% over all conditions
- Special 'catch spinning motor' operation supported
- Selectable high efficiency 2phase or 3phase PWM control modes to achieve reduced switching losses and EMI
- Low Thermal Resistance base plate for cold-wall mounting
- Operation in a high-vibration environment over –40 to 85C temperature range

Some applications need high torque at low speed. A Torque-Speed curve (Figure 4) shows the continuous and intermittent torque demanded of the sensorless speed controller for a typical PM motor application. From this diagram it is seen that the control should provide continuous torque at up to 200% for rated torque and 400% intermittent overload torque at 5% of full speed.

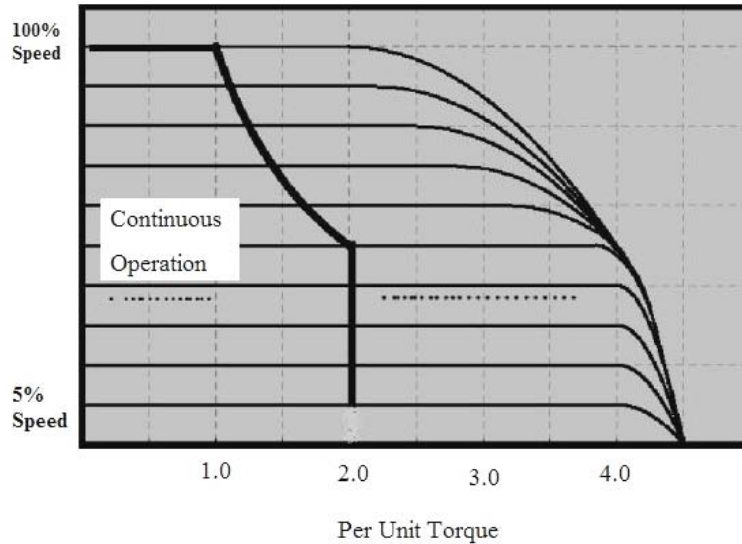

Figure 4) Torque Speed Curve

A startup retry function allows a pre-set number of retrials when the motor shaft is jammed or motor starting torque cannot overcome shaft startup friction. Figure 5) shows the retry sequence due to restraint of the rotor, which is subsequently released prior to the 4th try. The torque current (orange) and speed (blue) are shown followed by the phase current (green).

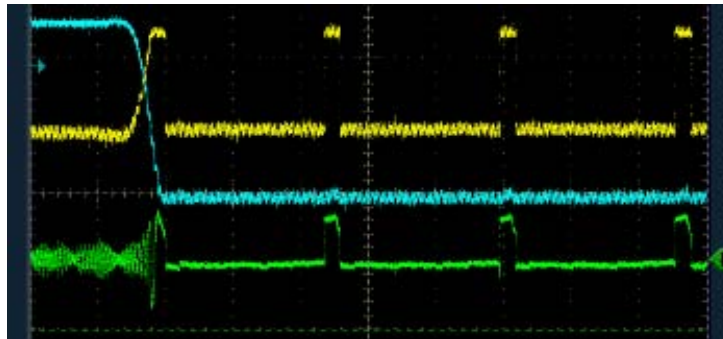

Figure 5) Retry Sequence

Configurable PWM Options

The configurable sensorless speed controller uses a versatile Space Vector PWM algorithm with several optional modes including 2phase/3phase, symmetric/asymmetric operation, and programmable deadtime.

Figure 6) illustrates the PWM waveforms for a Symmetric (center aligned) 3phase Space Vector mode of operation

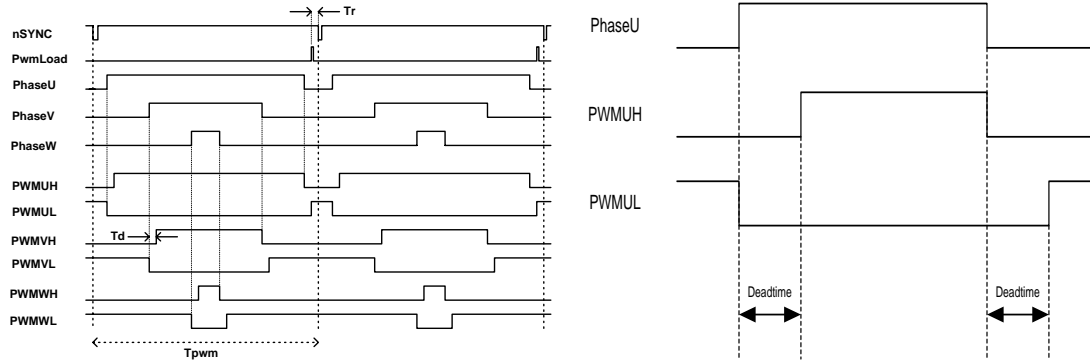

Figure 6a) 3-phase Space Vector PWM and 6b) Dead time Insertion (right)

Dead time, Figure 6b), is inserted at the output of the PWM Generation Module with a time resolution of 1 clock cycle, or 30 nsec at a 33.3 MHz clock. The dead time insertion logic inserts the programmed dead time between the high and low side gate signals for each phase. The dead time register is double buffered to allow “on the fly” dead time change and control while PWM logic is inactive.

Symmetric or Asymmetric operation is available for PWM waveform generation. With Asymmetric PWM mode, the inverter voltage the inverter voltage can be changed at two times the rate of the switching frequency, effectively doubling the bandwidth of torque control. Three-phase and two-phase Space Vector PWM modulation options are provided for the controller. The Volt-sec generated by the two PWM strategies is identical; however with 2-phase modulation the switching losses can be reduced significantly, especially when high switching frequency (>10Khz) is employed. After startup, the drive can be transitioned from 3phase to 2phase modulation for low-loss operation. There are two types of two-phase modulation schemes provided. Figure 7) illustrates the Inverter Pole voltage and motor currents for different types of Space Vector PWM strategies available.

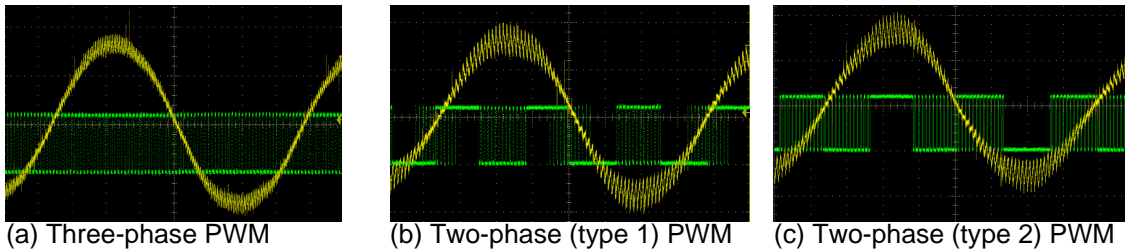

Figure 7. Different Types of Space Vector PWM

Hardware Description and Protection Features

Figure 8) shows the packaging for the sensorless speed version of the controller, rated at 1-5KW power output. Other packaging styles will accommodate very small space or higher power needs.

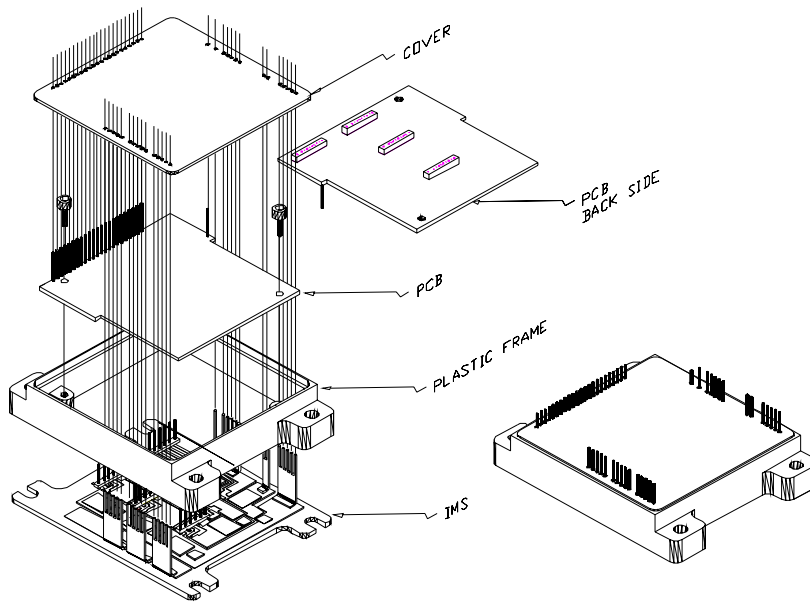

Figure 8) Packaging and Hardware (approx 3.7 x 2.9 x 1.5")

The control module sits atop the controller board stack and provides the control functions shown in Figure 2). Though the IRMCK203 ASIC is used in the initial platform, a reconfigurable FPGA is Planned for the control processor of the product. Future versions can re-host the HDL code onto the latest processing hardware with minor effort which extends the life-cycle of this product indefinitely.....obsolescence is a major issue with software based controllers and DSP's.

Underneath the control board is the Power Interface PCB, which contains gate drive, sensor interface, and protection features. IR2214 gate drivers are used on the Power Interface PCB. These are half bridge gate drivers rated for switching power devices with up to 750V common-mode output swing. These have low quiescent current, and manage all the half-bridge short circuit faults by detecting and turning off any IGBT, which goes into desaturation before the component is destroyed. A dedicated soft shut down pin signals current faults and helps to reduce EMI emissions.

A thermal clad Insulated Metal Substrate (IMS) is used as substrate and base-plate. IMS substrates are more mechanically robust than thick-film ceramics and direct bond copper construction and provide a cost effective solution. If extended temperature operation is expected, an AlN DBC substrate can be used instead. IR's Low V_{ce-sat}, fast switching NPT IGBTs and soft recover FREDs are soldered directly onto the substrate to reduce thermal resistance. A special coating is used to protect the die from humidity and contamination. A thermistor, mounted on the base plate, is used for overtemperature detection, with programmable setpoint of up to 130°C .

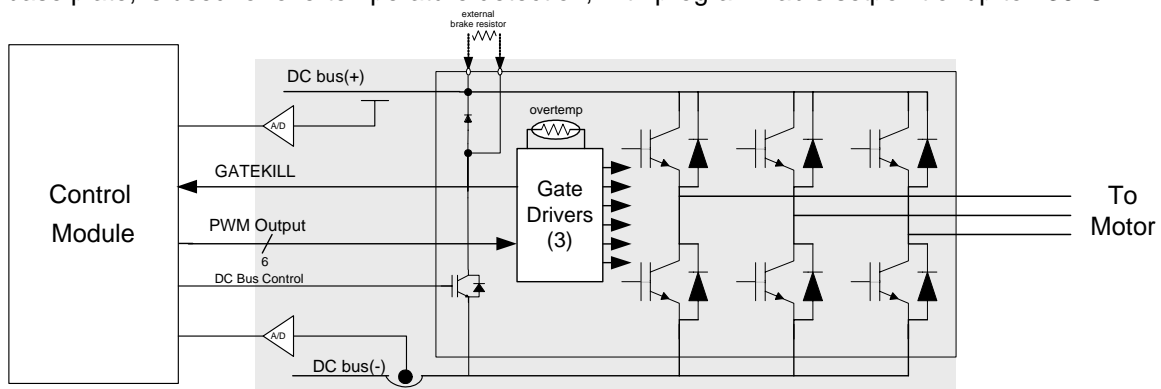

Figure 9) Protection Features

A desaturation event also triggers the GATEKILL signal which in turn initiates a fault response (soft shutdown). When an overcurrent condition occurs, all PWM output gate signals are disabled.

If Phase current sensing is done, Phase Loss detection is provided (during start-up) of a loose wire (u, v, w) between drive and motor.

Overvoltage and undervoltage trip levels are configured as drive parameters. An external braking circuit absorbs regeneration energy from the motor. The braking switch operates according to Bus voltage levels as a DC bus voltage limiter.

Other faults detected include Overrun and Zero speed faults

Drive Commissioning

A Start-up procedure is provided to guide the user through the commissioning of the user's motor application. Using a Drive Parameter Spreadsheet, the user enters high-level parameters which are translated into internal format and transferred to the host register interface in the control processor (using the ServoDesigner tool) through the communication interface.

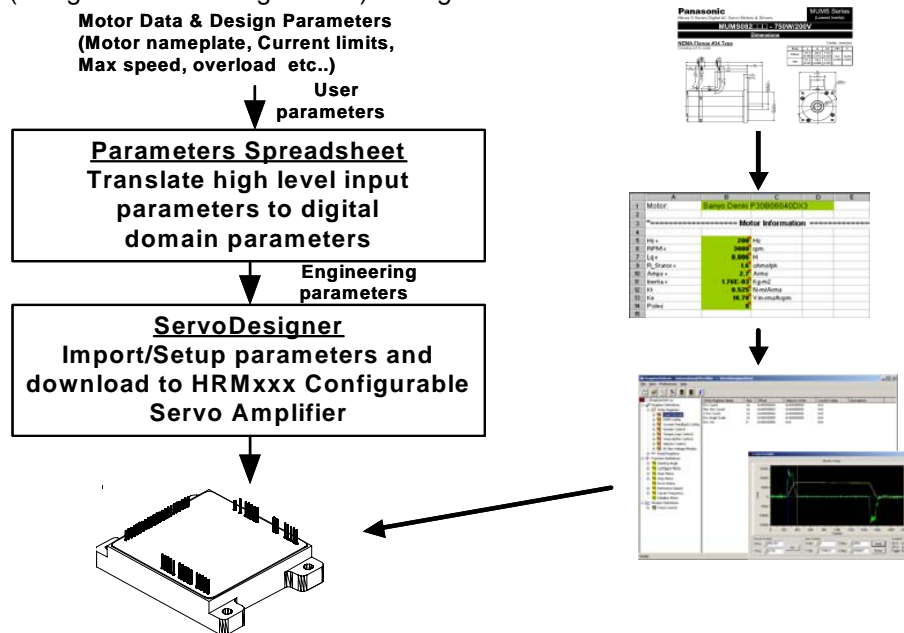

Figure 10) Drive Commissioning Process and Tools

The Drive Parameters spreadsheet helps automate the procedure of calculating the appropriate values for configuration and tuning parameters. In the spreadsheet, you enter motor nameplate and application data, and embedded formulas calculate the appropriate values to be written to the control's internal registers via a tool called ServoDesigner. A portion of the parameter spreadsheet is shown in Figure 10) with values appropriate for a typical servo motor

Application & Test Results

Figure 11) shows acceleration test results of an iMotion design platform with a 400W 3000rpm Synchronous PM motor

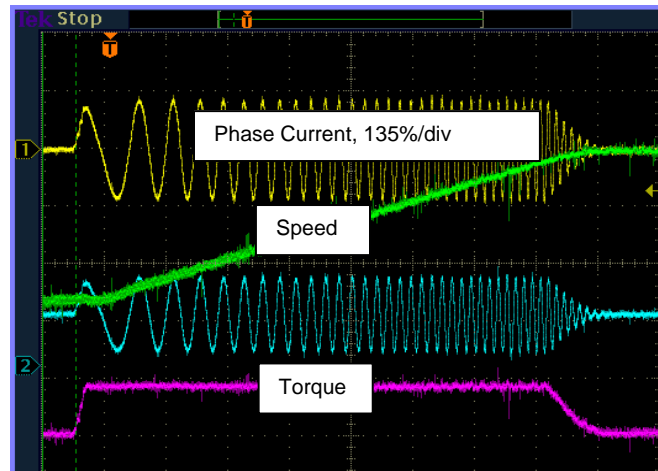

Figure 11) Acceleration (7% to 100% speed)

Some applications have space/size constraints and a single current sensor is desirable (also reduces cost). Figure 13 shows a liquid fluid pump operation test comparing 2 alternative methods of current sensing, 3leg shunt and single leg shunt. The single shunt approach is more challenging due to need for faster processing to reconstruct the individual waveforms for each phase of the 3phase bridge, and so is recommended for PWM speeds up to 20Khz. The configurable speed controller can support these methods plus the phase current sensing approach.

Pump Start-up Characteristics
 (0 to 1890 RPM, Time Span = 0.4 secs)

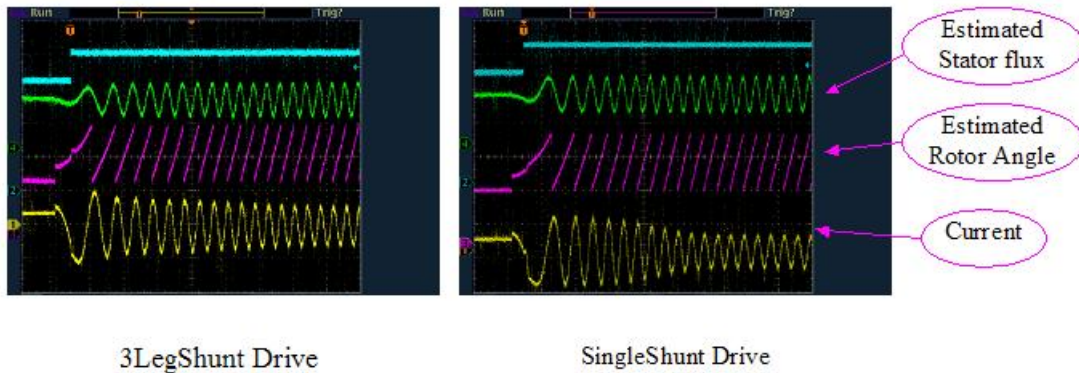

Figure 12) Pump Startup Characteristics with single leg and 3leg current measurement

Figure 13) shows a high speed spindle application start-up and shut-down with dynamic DCbus braking control.

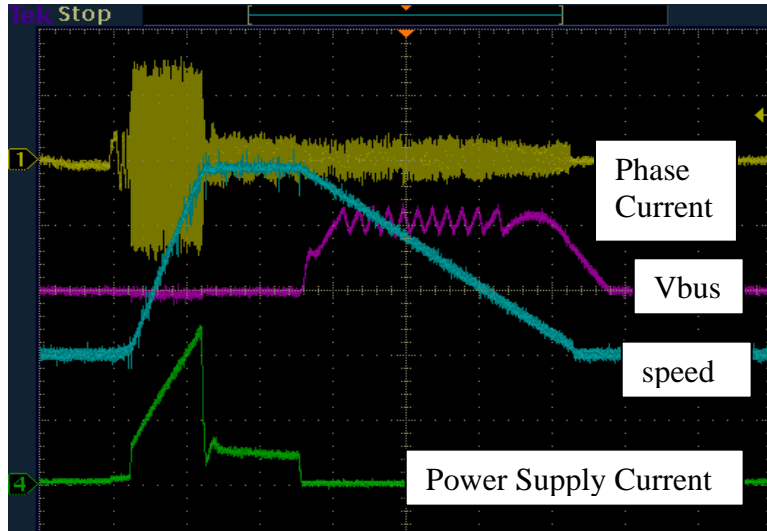

Figure 13) Spindle Start-Stop – speed 0 to +10krpm

Summary

A new sensorless closed loop vector speed controller has been introduced intended for use in rugged High Rel applications requiring a compact high performance solution.

This controller includes scalable power, performance, efficiency, and protection features. The code design can be implemented using the iMotion chipset as-is or re-hosted onto the latest hardware processing controllers (FPGA) with small effort which extends the life-cycle of this product indefinitely and facilitates product upgrades.

Future sensor-based controllers are planned for closed loop servo actuation of loads requiring accurate zero-speed and 4 quadrant control. These will also use an FOC vector control algorithm, but it is not sensorless.

Subsets of this controller are being considered for availability, such as the IPM portion or the Control Module portion of the controller.

References

- (1) "Sensorless, Sine-Commutated Speed/Torque Control of PM AC Synchronous Motors", Embedded Systems Conference – Feb 2004, J. Goetz and E. Ho
- (2) Ansoft Inc presentation "Rapid Design and Prototyping of Motors and Drives", Motors and Drive Systems 2004 - 2/3/2004
- (3) Second Dependable Software Technology Exchange – June 1994 - A report prepared for the SEI (software engineering institute) Joint Program Office HQ ESC/AXS, 5 Eglin Street Hanscom AFB, MA 01731-2116, Copyright© 1994 by Carnegie Mellon University
- (4) *Military & Aerospace Electronics*-Poly-Scientific expands 'Silencer' line of quiet and rugged brushless DC motors
- (5) *Military & Aerospace Electronics*-11/30/2001 Boeing to explore electric airplane
- (6) *Military & Aerospace Electronics* May, 1997 Electric drive to improve accuracy on Canadian turret
- (7) MotionControl.com Aug 25, 2004, Moog Announces \$50 Million Contract From Airbus